

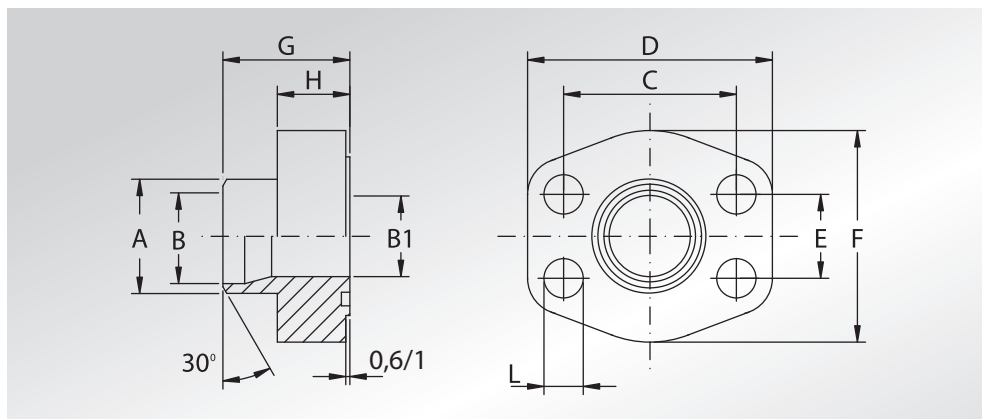

FLANGE A SALDARE DI TESTA TUBO METRICO

METRIC PIPE WELD ON FLANGES



Pressione max di esercizio raccomandata Kg/cm ²	Grandezza	Tipo	Dimensioni										Viti		Or tipo	Peso Kg
Maximum recommended working pressure Kg/cm ²	Size	Type	Dimensions										Screws		Or type	Weight Kg
			A	B	B1	C	D	E	F	G	H	L	Metric	Unc		

SERIE 3000

345	1/2"	AFS080SRE20	20	14	13	38,10	57	17,48	46	35	16	9	M8x30	5/16"x1"1/4	4075	0,24
345	1/2"	AFS080SRE22	22	16	13	38,10	57	17,48	46	35	16	9	M8x30	5/16"x1"1/4	4075	0,24
345	3/4"	AFS100SRE28	28	21,5	19	47,63	65	22,23	50	36	18	11	M10x35	3/8"x1"1/2	4100	0,35
345	1"	AFS102SRE35	35	27	25	52,37	70	26,19	55	38	18	11	M10x35	3/8"x1"1/2	4131	0,46
276	1"1/4	AFS104SRE42	43	36	31	58,72	79	30,18	68	41	21	11,5	M10x40	7/16"x1"3/4	4150	0,64
207	1"1/2	AFS106STRE48	49	42	38	69,85	93	35,71	78	44,5	24,5	13,5	M12x45	1/2"x1"3/4	4187	0,98
207	2"	AFS108STRE60	61	53	49	77,77	102	42,88	90	45	25	13,5	M12x45	1/2"x1"3/4	4225	1,14
172	2"1/2	AFS110STRE76	77	70	62	88,90	114	50,80	105	50	25	13,5	M12x45	1/2"x1"3/4	4275	1,55
138	3"	AFS112STRE88	90	82	74	106,38	134	61,93	124	51	26	17,5	M16x50	5/8"x2"	4337	2,33
34	4"	AFS116STRE114	115	107	102	130,18	162	77,77	146	48	26	17,5	M16x50	5/8"x2"	4437	2,85
34	5"	AFS118STREH139	140,2	131	120	152,40	184	92,08	180	50	28	17,5	M16x55	5/8"x2"1/4	4537	4,00

SERIE 6000

414	1"1/2	AFS405SRE60	61	40	38	79,38	112	36,50	94	56	28	17	M16x55	5/8"x2"1/4	4187	1,65
-----	-------	-------------	----	----	----	-------	-----	-------	----	----	----	----	--------	------------	------	------

DESIGNAZIONE PER ORDINE DESIGNATION FOR ORDER	Materiale / Material	
	S355	AISI 316L
Solo flangia Only flange	AFS...SRE/STRE	AFX...SRE/STRE
Flangia completa di viti metriche, grower e o-ring Flange complete of metric screws, grower type washers and o-ring	AFS...SRE...M/STRE...M	AFX...SRE...M/STRE...M
Flangia completa di viti unc, grower e o-ring Flange complete of unc screws, grower type washers and o-ring	AFS...SRE...U/STRE...U	AFX...SRE...U/STRE...U

NOTE / NOTES

set viti unc disponibili solo in acciaio al carbonio
unc screws set available only in carbon steel